

PRODUCT SPECIFICATIONS

Luminex 40GBase Direct Attach Cable 1m

Description: Technical specifications Luminex 40GBase Direct Attach Cable 1m.

Luminex reserves the right to modify the technical specifications at any given time without prior notice.
No rights can be claimed from these specifications.



MADE IN BELGIUM

Technical Specifications

Features				
QSFP MSA				
Hot pluggable				
Industrial temperature range				
Environmental				
Operating temperature	-40°C to 85°C			
Storage temperature	-40°C to 85°C			
Humidity	5-85% RH			
Connectivity				
	QSFP+			
DAC cable length				
	1m			
Max data rate				
	40Gbps			
Regulatory compliance				
EMI/EMC: EN55032:2015+A1:2020+A11:2020				
EN55035:2017+A11:2020				
ENIEC61000-3-2:2019/A1:2021				
EN61000-3-3:2013+A1:2019				
FCC Part 15, Subpart B:2016				
RoHS: Compliant with EU RoHS 2.0 directive 2015/863/EU				
Mechanical				
Parameter	Minimum	Typical	Maximum	Unit
Cable Diameter (30 AWG)	-	6,5	-	mm
Bend Radius (30 AWG)	44	-	-	mm
Cable Insertion Loss	-	10	-	dB/10m
Bulk Cable Crosstalk	-	-	1	%
Insertion Force	-	-	20	N
Withdrawal Force	-	-	12,5	N
Retention Force	90	-	-	N



Technical Specifications

Mechanical

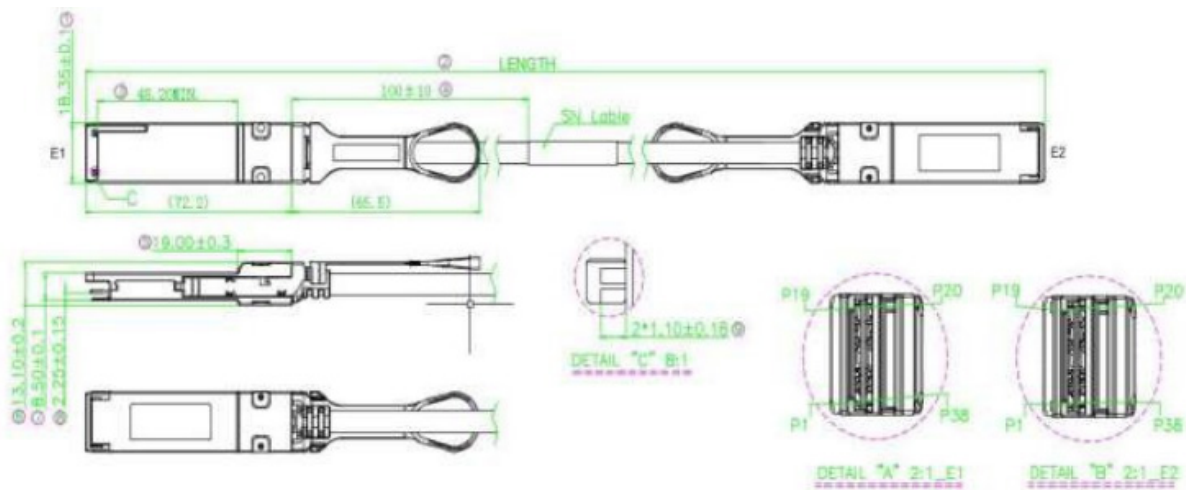

weight (g)	324
Housing material	Metal
Packaged weight (g)	348
Packaged Dimensions (mm)	26x26x12

